Peter Mcilwain

Monash University
School of Music -Conservatorium
Monash University, 3800
Australia
peter.mcilwain@arts.monash.edu.au

Jon McCormack

Monash University
Centre for Electronic Media Art
Monash University, 3800
Australia
jon.mccormack@infotech.monash.edu.au

Alan Dorin

Monash University
Centre for Electronic Media Art
Monash University, 3800
Australia
alan.dorin@infotech.monash.edu.au

Aidan Lane

Monash University
Centre for Electronic Media Art
Monash University, 3800
Australia
aidan.lane@infotech.monash.edu.au

Composing With Nodal Networks

This is my music:

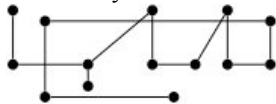

A graph drawn by Stravinsky when asked to visually represent his music (Craft, 1962).

Abstract

Issues related to compositional technique using the software environment Nodal are discussed. The particular focus in this paper is the use and characterisation of nodal networks. These networks are the generative engine of Nodal. Network configuration is explored by discussing the compositional process for the work “Network Study #1” that employs Nodal exclusively. Observations are made regarding the transformational properties of simple networks.

Introduction

Nodal is a software environment that enables the configuration of nodal networks for the generation of music. Its user interface employs a graph-based representation of networks that are created and edited by the user in real time. Nodes “fire” and pass messages to other nodes via connections (or edges) between them. Upon firing, a node makes a musical note (defined by standard MIDI

parameters). Inter-onset times between notes, and therefore node firing patterns, are determined by the length of edges between the nodes as represented in the graph. The relationship between node configuration and musical output is illustrated in Figures 4 & 5 below. A full description of the design and implementation of *Nodal* can be found in our previous paper (Mcilwain & McCormack, 2005).

While graphs have been used for the representation of musical structures for some time, the use of dynamical networks for the generation of music is relatively new. *SNet* is an example of the use of networks for music generation that simulates the behaviour of biological neural networks (Mcilwain & Pietsch, 1996). The output of the software generates inter-onset time and spatial position of sound source. More recently simple generation systems have emerged that use limited networks manipulated by intuitive user interfaces. *Block Jam*, for example, is a “tangible interface” that uses physical blocks that function like nodes. The blocks can be connected together like dominos to make generative networks (Newton-Dunn, Nakano & Gibson, 2002). A similar example is *Composition on the table* (and its successor, *Electroplankton* on the Nintendo DS device) by Toshio Iwai (Iwai, 1999). Here software actors traverse a fixed geometrical network (where distances between nodes represent inter-onset time). Variation in traversal is obtained by changing connection rules in the nodes. This is

achieved by simply clicking on a node to cycle through a number of fixed connection possibilities. Connection rules are developed further in Dorin's *Boolean Network* software (Dorin, 2000). Here Boolean functions are applied to binary state nodes. Node firing is dependant on the state of neighboring nodes.

While the examples above are simple and elegant solutions to the problem of interactive programming for networks they are very limited in terms of the number of possible configurations, particularly in relation to variation of inter-onset time and network topology. *Nodal* on the other hand permits a very wide range of possibilities and as such offers an appropriate environment for the exploration of compositional techniques using generative networks. However, this expanded set of possibilities raises the problem of how to configure and control networks in musically useful ways.

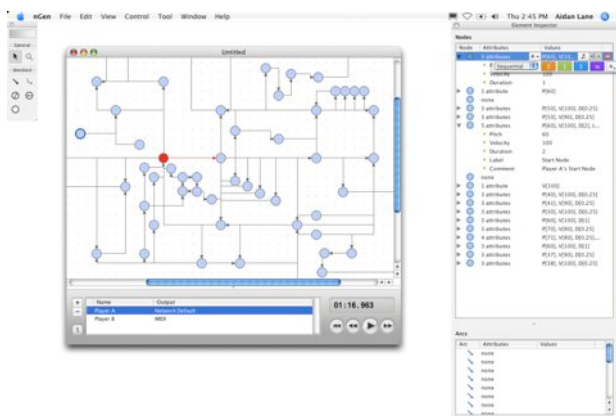

Figure 1. Screen shot of *Nodal* in operation.

Composing in a Sea of Possibilities

The number of possible configurations of networks in an environment such as *Nodal* is very large; too large to allow an ordered or iterative search of all possible network configurations. Therefore, it would seem practical that any approaches to composing music with it should start with an investigation of the musical properties of a limited set of networks: those that may have useful musical properties or behaviours. However, even small networks can have an unmanageably large problem space. For example, three nodes in a directional, connected graph, can have 64 possible configurations and 4 nodes can have 4096¹, and these figures are limited to simple connection rules that are discussed below. This is a typical problem in creative environments designed for computers. The tendency is to design them to afford the maximum number of possibilities, which in theory allows for almost any type of music to be made (within the constraints of the given environment), but which in practice usually results in the exploration of a very lim-

¹ The formula below can be used too calculate the number of possible configurations for a specific number of nodes.

$$c = 4^{\binom{n(n-1)}{2}} \quad \text{where } n \text{ is the number of nodes.}$$

ited set of possibilities. This is because the size of the problem space allows only experimental compositional approaches unless more sophisticated and structured procedures have been developed.

This kind of problem is not uncommon in music. For example the investigation and formalisation of scale and harmony has seen, over the space of many centuries, the distillation of two main scales from a multitude of potential scale types. While it is the case that harmonic and polyphonic practice often evolved ahead of formal theoretical models (Powers, Wiering & Porter 2006), there are many instances where the formalisation of compositional procedures have led to a flowering of compositional investigation. One of the best examples of this is the development of the twelve-tone serial technique by Schoenberg.

In order to navigate the “sea of possibilities” that *Nodal* offers it is necessary to develop criteria by which we can limit the type and number of networks. These selected networks are characterised and compared in terms of their compositional utility. The criteria adopted here is as follows:

1. all networks (or graphs) should be limited in size;
2. networks should loop continuously (not halt);
3. nodes should have simple connection rules,
4. all distances between nodes must be limited to whole number ratios of each other.

1. Size

The best way to characterise a limit of graph size is according to the number of edges (or connections). Here the limitation is for graphs in the order of 12 edges or less. It is important to note that limitation of the number of edges also limits the number of maximum possible nodes. Note that this is not the same as a limit by the number of nodes, for example 10 nodes in a directed graph can have a maximum of 45 edges which can give rise to behaviour that is considerably more complex than networks that are limited to 10 edges.

2. Continuous Loops

While it may be useful in some circumstances to use networks that do not continuously loop, linear networks are excluded from this study on the grounds that linear composition can already be done with traditional compositional methods. The benefits of the nodal approach lie in the potential for evolution and variation through iterative behavior. Given that the each network must loop it is not necessary to determine which is the starting node for any particular network.

3. Simple Connection rules

In this study, connection rules are limited to the following criteria:

- for every input there is a corresponding output;
- all inputs are treated as one input (as shown in Figure 2);
- multiple outputs are selected sequentially, i.e. each time the node is activated the $n + 1$ th output is selected if the previous output was n . When the last

output has been selected the first output is the next selected.

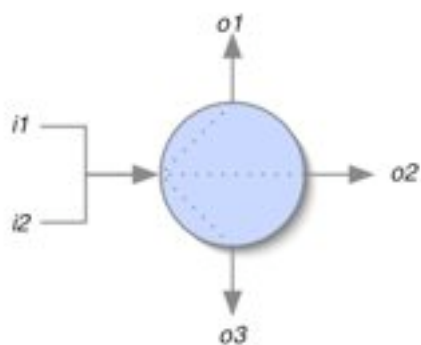

Figure 2. Successive input from either *i1* or *i2* will cause output in the following sequence: *o1*, *o2*, *o3*, etc.

Nodal is capable of dealing with more complex connection rules, such as parallel or random output firing, however these rules can lead to highly complex outcomes and not the subject of this current analysis.

4. Whole number distances

The last limitation, that all distances between nodes must be limited to whole number ratios of each other simply describes a basic limitation that is an intended property of the design of *Nodal*. Here nodes are positioned with a “snap to grid” function. This quantises the space between nodes to whole number units, thus avoiding time cycles that are too complex to hear or work with¹.

Categorisation

The limitations discussed above reduce the size of the problem space considerably. For example, the number of possible configurations for 3 nodes is reduced to 4 as opposed to 64. As a result it is now possible to look at the most simple graphs and explore these as basic building blocks. Some of these are shown in Figure 3. There are two ways in which these basic graphs can be explored. Firstly as elements that can be combined to make larger networks. This approach is similar to the technique in which complex rhythms are derived from simple 2, 3 and 4 beat patterns. This is typical of the kind of rhythmic construction found in much of Bartok’s music. The piano work from *Mikrokosmos No 148*, (*Six Dances in Bulgarian Rhythm No. 1*) is a good example of this (Bartok, 1940). Secondly, basic networks can be seen as the embryonic form for a family of related networks. In this approach, the relative placement of nodes defines sets of rhythmic units, and the number and configuration of the edges in the graph, define the order in which these elements are sequenced. This is the approach that has been adopted in the study work discussed below. The “family” of networks relating to this work is shown in Figures 4 & 5.

¹ Nodal has an option to turn this function off, however an exploration of the possibilities this presents is the subject of future investigation.

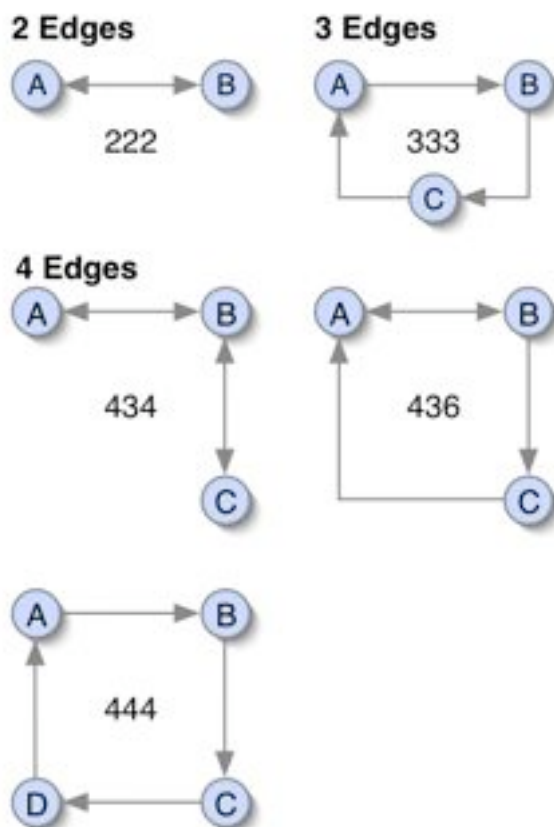

Figure 3. Possible graphs from 2, 3 and 4 edges. Edges can be either unidirectional or bidirectional (bidirectional edges are counted as two edges).

The discussion above leads to the suggestion that it is musically useful to find relationships between the networks (that fit the criteria described above). A naming system can be adopted that assists with this by describing the number of edges and nodes in a graph as a prefix. For example a network with 4 edges and 3 nodes could have a prefix of 43. If we include a third element in the prefix, the length of one loop or circuit, through the network², then we have very specific naming system. For example 4 edges and 3 nodes will can have a loop length of 6, so the prefix can now be: 436.

Rhythmic Possibilities

The overriding feature of the behaviour of networks examined here is the tendency for loops to have time cycles other than units of 2 (and most particularly the ubiquitous cycle of 4). Furthermore it is likely that in all cases, changes to the number of edges in a network will result in a different time cycle. This property suggests a number of important structural issues with regards to the organisation of rhythmic elements. Firstly, that in all but the most simple of configurations, time cycles will vary. Figure 4 illustrates this with a simple cycle in 3, which can easily be altered into a cycle of 11 by the addition of 2 extra edges.

² the unit of measurement here is the resolution of beat divisions that can be set as a user parameter in Nodal.

Secondly the natural variation in time cycles suggests musical textures that do not conform to metrical structures but rather layered pulse structures as is typical of much 20th Century art music, particularly the work of Stravinsky (Cross, 1998), Messiaen (Messiaen, 1956) and minimalist composers such as Reich (Schwartz, 1996).

a.

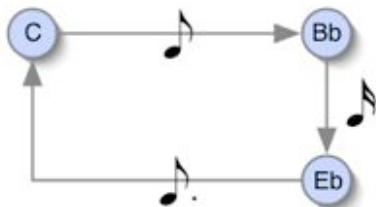

b.

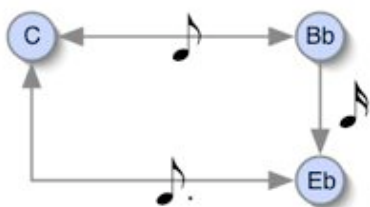

Figure 4. Rhythmic variation by the addition of edges.

Centricity

Figure 4 also illustrates the propensity for pitch centricity as a result of network design. If a graph has an equal distribution of pitches (as is the case in Figure 4), then simple configurations may not necessarily have a pitch focus. In Figure 4a, a pitch focus is not established by pitch frequency, however it may be inferred by agogic stress in that the Eb has the focus since it has the longest duration. When the cycle is longer, agogic stress is less of a factor, but we do see in Figure 4b a greater frequency of the pitch C than for Bb or Eb. This will weight the perception of a pitch centre to C.

Given the above we can see that different configurations of edges can give rise to different pitch centres. Therefore a piece created with *Nodal* that uses a number of network configurations, may have multiple pitch centres. This property also suggests similarities with minimalist textures (Schwartz, 1996) where centricity is not established as a result of functional harmony, particularly as the rhythmic structures do not afford cadential routines. It also indicates that pitch centres are likely to be ambiguous or mobile unless a particular network circuit is constructed to provide a pedal or drone.

Observations from Practice

In order to discuss the compositional possibilities of *Nodal* a short work, *Network Study #1*¹ was composed that takes into account some of the features and behaviours discussed above.

One of the striking features of nodal networks are their capacity to transform a simple musical cell – Figure 4 is an example of this. There are a number of ways in which transformation can occur, particularly in relation to time and rhythm:

- the addition of edges will create differences in time cycle and duration of particular pitches (in relation to time points in the cycle);
- the addition of nodes will have a similar effect to the above whilst adding more pitch material;
- the movement of nodes relative to other nodes can create different time points in a cycle and alterations to the time cycle (this is particularly noticeable when a node is moved that has bidirectional connections);
- the replacement of pitch material in a network.

Given that the transformational possibilities are extensive, the central idea in the study work was to explore a coherent set of transformations. This was done in order to give the composition shape and direction via a process of change. This concept relates strongly to Reich's ideas on process pieces (Mertens, 1983).

As a starting point, the network in Figure 4a was selected and variants of it were made by the addition of extra edges – these are shown in Figure 5. This created a set of 8 cells that vary in the lengths of their time cycles but are closely related in rhythmic structure.

¹ *Network Study #1* is composed by Peter McIlwain using *Nodal*. The

score and MIDI file is available at:

<http://www.arts.monash.edu.au/music/mcilwain/nodal.html>

a.

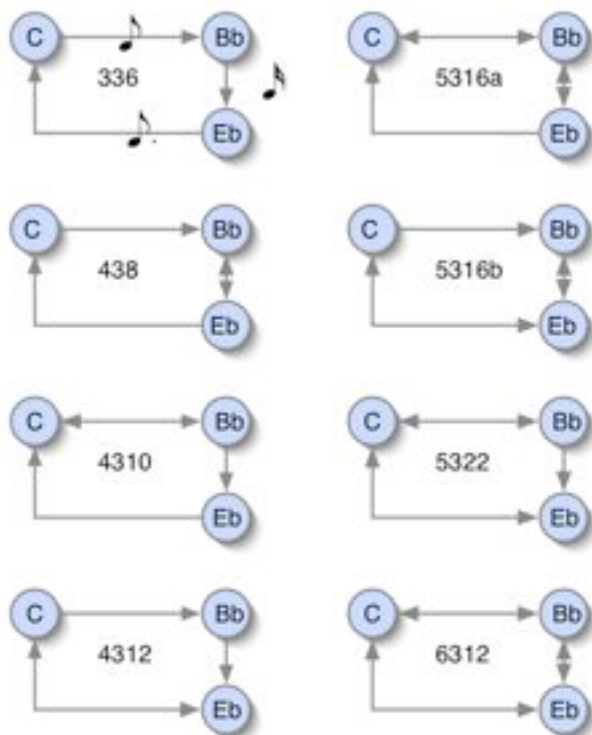

b.

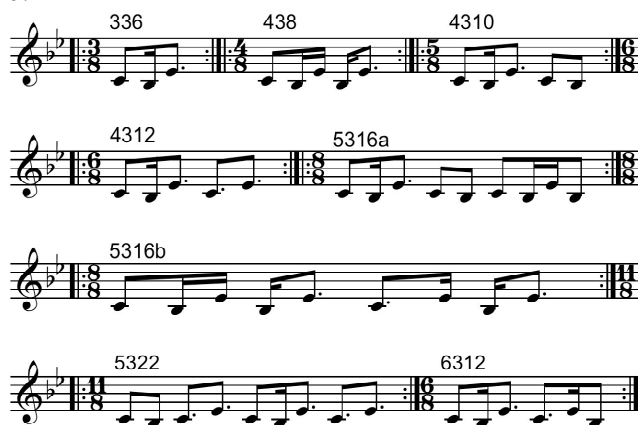

Figure 5. Basic motivic material in *Network Study #1*. a) graph design, b) corresponding notated output.

These 8 cells can be grouped according to time cycle as follows:

- in cycles that are multiples of 3 (336, 4312 & 6312)
- in cycles that are multiples of 4 (438, 5316a, 5316b)
- in asymmetric cycles (4310, 5322)

This gives three chains of motivic material, each of which progress from shorter to longer time cycles. The cells above are therefore organised into a texture by following these progressions and by looking for interesting phasing effects using the combination of differing time cycles from the three streams. For example, the piece starts with a combination of 5 against 3 (4310 & 336).

Extensions of these cells were made by the addition of more nodes with new pitch material. This created extended thematic material that added contour to the surface of the texture and provided a melodic role.

To complete the piece the process of movement from shorter time cycles to longer ones was reversed. Therefore the piece finishes with a 3 against 5 texture, but unlike the opening the long melodic streams are layered over the top. This gives a shape that has similarities with traditional ABA form although it is important to note that block forms are not easily achieved in *Nodal* for reasons discussed above. In this case there are no distinct points that can be said to be sections, since the various layers overlap. Once again this kind of structure is typical of much 20th Century music starting with Debussy right through to dance and techno.

Evaluation

Network Study #1 demonstrates that Nodal is capable of generating music with a coherent structure using simple network designs. This coherence stems from the propensity for rhythmic transformation and extension of basic motivic material.

The textures that occur in the piece do feature phasing however in most instances (except in the opening section) this is not apparent. This is due to the fact that there are often three cycles happening at the same time. The point at which the cycles come into phase is never reached. On the other hand, the simultaneous presentation of different time cycles does give rise to a shifting counterpoint, which is interesting and attractive. This contrapuntalism creates a sense of depth to the texture, as the differing cycles highlight, or enable the distinction of different layers within the texture (so that there is a sense of “layer behind layer”).

The shift from short to longer time cycles as described above does give a shape to the composition requiring a change in perspective on the part of the listener as the longer melodic material is presented. Here there is a sense in which the texture seems to open out and become more expansive. This demonstrates that significant changes in texture are possible.

Conclusions and future work

There is scope for the investigation of the behaviour of nodal networks well beyond the bounds of the work presented here. In particular much could be done in relation to studying networks as complex systems, e.g. (Watts, 1999). Whether this extent and level of enquiry is warranted in relation to *Nodal* depends on how likely it seems that nodal networks are in fact musically useful. Therefore the focus of this paper has been on illustrating practical approaches to the use of networks.

Although the work discussed here indicates that long term structure is possible by selection of specific networks, it remains to be seen whether it is possible for users to create more complex networks that generate long term structure. One possible area of future work is the development of connection rules that effectively turn edges on and off. This would be a powerful form of control over network behaviour in terms of complexity and musical density. This kind of control could go a long way towards providing a system that is capable of com-

plex evolving behaviour, while at the same time allowing long term shaping of density and complexity.

It can of course be argued that in seeking more integrated and long-term structures one misses the point of using non-linear process for the generation of music. A counter to this is that in general, the perception of musical transformation is linear and that complex evolution, which can (and often does) work in the context of non-linear visual arts, is not apparent in the time oriented, linear world of music.

References

- Bartok, B. 1940. *Mikrokosmos Vol. VI*. London: Boosey and Hawkes. 35-8.
- Cross, J. 1998. *The Legacy of Stravinsky*. Cambridge: Cambridge.
- Craft, R. 1962. *Conversations with Igor Stravinsky*. Harmondsworth: Penguin. 121.
- Dorin, A. 2000. "Boolean Networks for the Generation of Rhythmic Structure" Proceedings of *ACMC 2000*. eds, Brown. and Wilding. Australian Computer Music Conference. 38-45.
- Iwai, T. 1999. "Composition on the table." *SIGGRAPH1999 Proceedings*. New York: ACM Press.
- Powers, H.S. Wiering, F. and Porter, J. "Mode I-V" *Grove Music Online*. ed. L. Macy. <http://www.grovemusic.com> (7th June 2006).
- McIlwain, P. and McCormack, J. 2005. "Design Issues in Musical Composition Networks" Proceedings of the *Australasian Computer Music Conference 2005*. Fitzroy, Australia: ACMA. 96- 101.
- McIlwain, P.A. and Pietsch, A. 1996. "Spatio-temporal Patterning in Computer Generated Music: A Nodal Network Approach" Proceedings of the *International Computer Music Association Conference 1996*. San Francisco: ICMA. 312-15.
- Mertens, W. 1983. *American Minimal Music*. London: Kahn and Averill. 54.
- Messiaen, O. 1956. *The technique of my musical language*. Paris: Alphonse Leduc.
- Newton-Dunn, H. Nakano, H. and Gibson, J. 2002. "Block Jam" *SIGGRAPH2002 Proceedings*. New York: ACM Press.
- Powers, H.S. Wiering, F. and Porter, J. "Mode" *Grove Music Online*. ed, L. Macy. <http://www.grovemusic.com> (7th June 2006).
- Schwartz, K.R. 1996. *Minimalists*. London: Phaidon.
- Watts, D. 1999. *Small Worlds*. Princeton: Princeton.
- Wilson, R.J. and Watkins, J.J. 1990. *Graphs: An Introductory Approach*. New York: Wiley.

Appendix

The image displays a dense musical score for a large ensemble, possibly a symphony or orchestra. It consists of numerous staves, each containing musical notation such as notes, rests, and dynamic markings. The notation is arranged in a grid-like fashion, with vertical lines indicating the progression of time across the staves. The score is presented in a black and white format, typical of a printed musical score. The overall appearance is that of a highly detailed and complex musical composition.

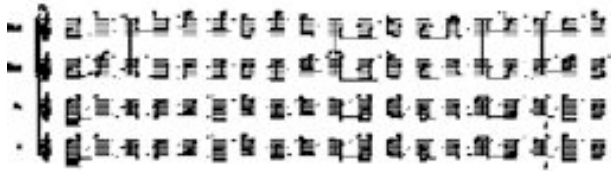
1. 

2. 

3. 

4. 